

Digital transmission in pressure sensors

When accurate values are required in an application, digital sensors are superior to analog instruments. Particularly in automotive engine test benches, accurate pressure measurements are a must.

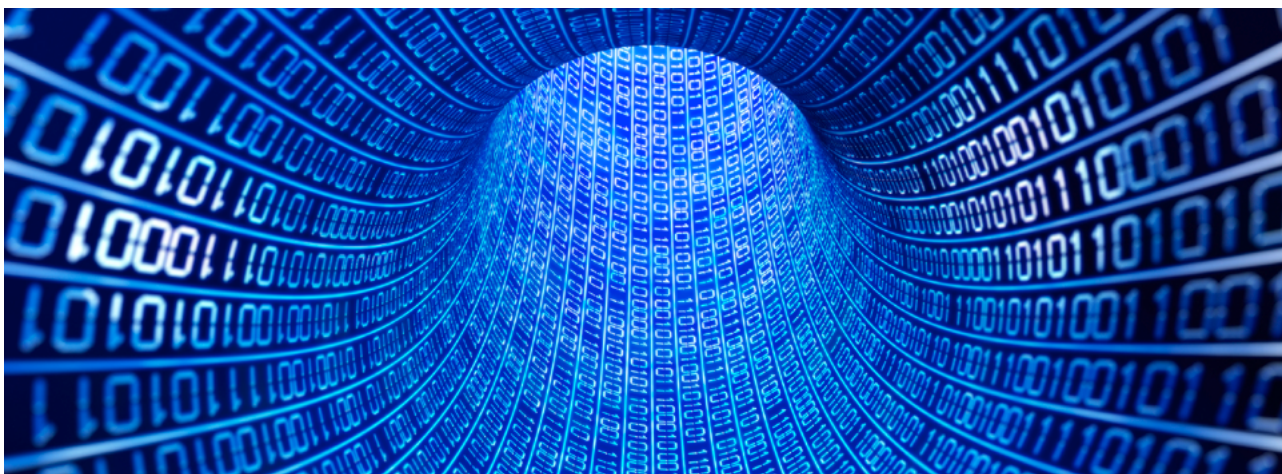

We take a look at the basic design of both analog and digital sensor measuring chains, and also typical error influences. The differences in the wiring and signal evaluation lead to error model calculations that are clearly different from each other. Thus in our example, with lower investment costs, a digital measuring chain can achieve an overall accuracy of 0,1 % while also being more resistant to external interference by design.

Whenever accurate measured values are required in an application, the advantages of digital sensors, compared to analog instruments, become obvious. When talking about digital sensors, we mean sensors with an integrated analog-to-digital conversion, which uses a digital interface to transmit the measured value (e.g. CANopen or USB) with the pressure value transmitted as a numeric value. An analog sensor, however, has no built-in analog-to-digital conversion and transmits its signal as an analog current or voltage signal, e.g. 4 V mA to 20 mA, or 0 V to 10 V.

Therefore, in applications where high accuracy is required, for example in test stands for propulsion technology, it is advisable to use digital sensors. This avoids further sources of error that exist in analog instruments, over and above the signal conditioning, as a result of the analog signal transmission. Figure 1 shows the schematic design of a typical analog pressure sensor. By the deformation of a diaphragm under a pressure load, a resistance change occurs in the resistance bridge fixed to the diaphragm. This change in resistance is converted into an electrical signal, amplified and transformed into a standard signal. The compensation of the sensor-specific errors (zero error, span error, non-linearity) is also made through analog circuit technology, for example, resistance networks. With digital sensors, however, the electrical signal of the resistance bridge is directly

converted into a digital value and the subsequent compensation is instead made mathematically in a microprocessor (see Figure 1). Here, depending on the required accuracy, non-linear errors of any order can be compensated and accuracies up to 0,05 % can be achieved at low costs. By using a μC , an active temperature compensation is also possible, eliminating any temperature error within a defined temperature range. This compensated digital signal now exists in the pressure transmitter as a numerical value and then can be output via any digital protocol (e.g. USB, CANopen, etc.). During the onward transmission of this digital pressure signal, it is now immune to interferences which might cause a further deterioration in the accuracy.

If we compare the complete analog measuring chain with its digital counterpart, the advantages of digital sensors become even clearer. Figure 2 shows the schematic structure and at which point external interferences, such as EMC or temperature, introduce additional errors.

Initially, the analog front end of both sensor principles is adversely affected by environmental influences such as temperature fluctuations, EMC, etc. However, in the case of the digital pressure transmitter, the pressure signal is no longer influenced by external effects after the AD conversion. In the case of the analog signal chain, even the internal compensation is subject to possible temperature effects due to passive components. The output driver that generates the standardized output signal (e.g. 4 mA to 20 mA or 0 V to 10 V) is also constrained by a variety of external influences (cable length, input impedance of the signal evaluation, temperature, EMC, etc.). Anyone who has tried to evaluate an analog sensor signal with high precision will also know the problem of signal noise. Even in the unpresurized state, the evaluated signal is not fixed at 4 mA but

fluctuating within a particular range, e.g. 3985 mA to 4007 mA. This is mainly due to environmental influences which the signal cable picks up, acting as an "antenna".

For further processing, this analog signal value must be digitized, if only for visualization on a display or as a control variable for a controller. I/O channels of programmable logic controllers (PLCs) or external A/D modules can be used for this. These components are also subjected to environmental factors that have a negative impact on the accuracy of the measured value acquisition. Thus, these A/D evaluation modules also have a specified accuracy, which is the best to which they can determine an analog signal. This means that the inaccuracy of the sensor itself is further added to by a deterioration in accuracy at the A/D module. This error through the A/D conversion, in turn, is also temperature dependent and, at the limits of the operating temperature range, will become even larger.

In digital signal transmission, the overall accuracy of the measuring chain is influenced solely by the inaccuracy of the sensor. Following the A/D conversion within the sensor, the pressure is available as a numerical value. This can be adapted through a microprocessor to any digital bus signal (CANopen, USB, Profibus). This adaptation has no influence on the accuracy specification, nor is the transmission of the digital signal subject to any influences that would degrade the accuracy. So, with the example of CANopen as the transmission protocol, cable lengths of 1000 m are possible without any effect on the accuracy of the pressure signal. Moreover, no additional error occurs

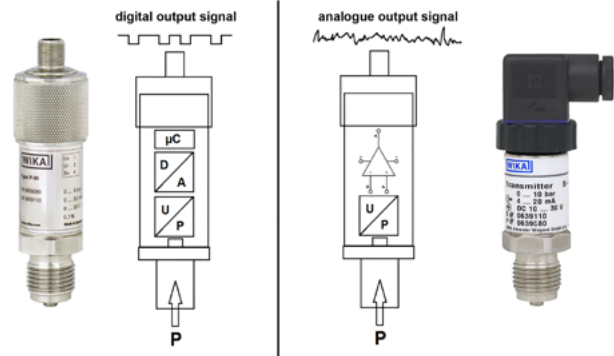
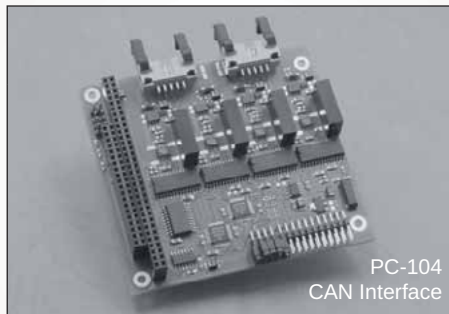
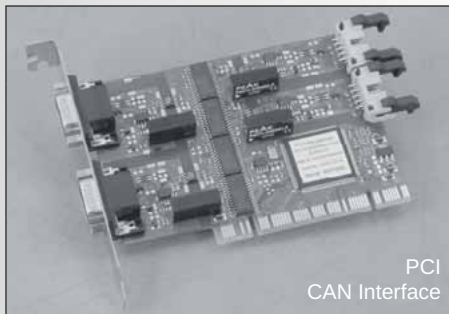
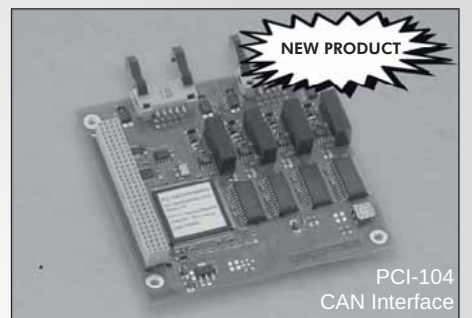
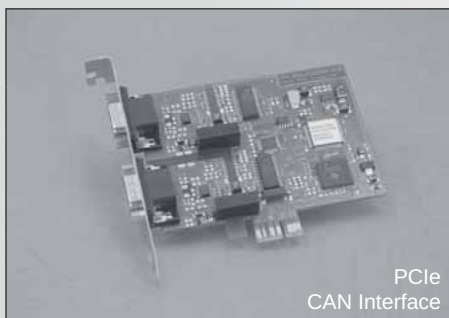

Figure 1: Design of a digital pressure transmitter vs. an analog pressure transmitter

at the signal evaluation end. There, one finds a digital bus master, which reads the digital values from the bus and forwards them to the appropriate software/process control element. This all takes place with a digital numerical value, unaffected by any environmental influences.

For the sake of completeness, it should be mentioned that strong EMC interferences can also affect digital bus signals. If a pulse-shaped interference is superimposed, a "0" could arrive in the master as a "1". However, this again shows the advantage of using microprocessors that can detect and correct these errors with their built-in "intelligence".

During transmission, algorithms built into the sensor and the PLC ensure that transmission errors are detected. For this, checksums are calculated from the measured >



CAN Interfaces for Your Requirements

- Economical solutions for series applications
- Optimized for industrial applications
- Solutions for stationary and mobile use
- Software support for bus-analysis, measurement and control

www.ems-wuensche.com

EMS Sonnenhang 3
D-85304 Illmünster
Tel. +49-8441-490260
Thomas Wünsche Fax. +49-8441-81860

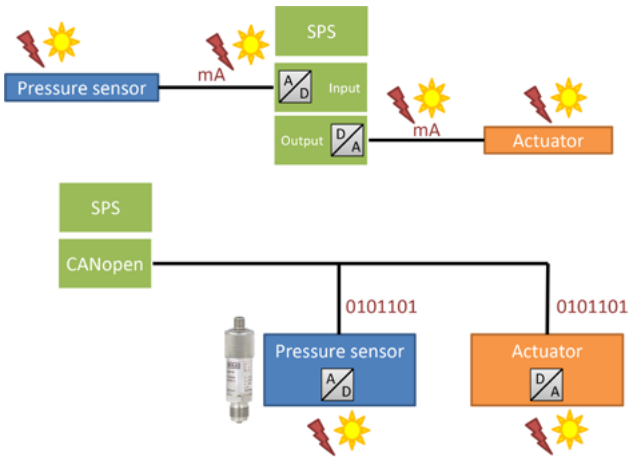

Figure 2: Analog and digital measuring chains in comparison

values by using cyclic redundancy checks (CRC) and for any discrepancies the measured value will be discarded and requested again. To some extent, it is also possible to calculate the correct measured value from the transmitted checksum and thus the transmission errors generated can be corrected. This then avoids re-transmissions and the associated loss of time.

In the digital measuring chain design, it is not just the susceptibility to error that is reduced, but also the amount of wiring. Each sensor and actuator no longer needs its own signal line, but rather many nodes can be connected via a single, branched line. In the case of CANopen, up to 127 nodes can be connected to a PLC input card via a single cable with three lines (CAN_H, CAN_L, GND).

Many manufacturers now operate on the basis of identical component strategies when configuring digital sensors – the compensated pressure value is then ready to be transformed back to an analog standard signal through a D/A conversion. In the context of the comparison of analog and digital sensor technology, this is almost the worst strategy. Here, the digital, compensated, “clean” sensor signal is converted back into an analog value that can be distorted by the effects of temperature, quantization errors, and other disturbances. Thus it makes sense, once the effort of processing the sensor signal into a digital one was already made, that it should be transmitted digitally to the PLC, eliminating further sources of error.

After comparing the basic construction of the measuring chains, we should now also look at the advantages using a calculated example of an accuracy assessment. Pressure sensors are available in both digital and analog versions at reasonable prices with accuracies of up to 0,1 %. This accuracy should be used as a baseline in both cases.

In the example of the analog signal chain, an error of about 0,1 % can occur along the path of transmission. High contact resistance at the connection points in the case of 0-V to 10-V signals or the superposition of electromagnetic interferences (e.g. in the vicinity of pumps or motors or other potent sources of interference) can be the cause of these effects along the transmission line.

Low-cost analog input modules offer resolutions in the range of 10 bit to 14 bit and possess a basic accuracy of 1 %. Of course, this error is then added to the error of the sensor. With these specified accuracies, however, only the accuracy at the reference conditions is covered – if one moves outside of these reference conditions, further errors are accrued. Typical values here are in the range of an additional 1 % temperature error over the entire temperature range.

Even analog input modules of the highest quality, with up to 24-bit resolution, still have inaccuracies of 0,1 %. And still, with these modules, additional temperature errors must be taken into account – although these are very low, they can still be in the range of 10 ppm/°C. For a module that can be used in the range of -40 °C to 125 °C, this would constitute an additional error of 0,165 % over the temperature range.

Purely mathematically, the two cases are represented as follows:

- ◆ “Low-cost” analog input module:
 $0,1 \% \text{ (pressure transmitter)} + 0,1 \% \text{ (transmission path)} + 1 \% \text{ (analog input module)} + 1 \% \text{ (analog input module temperature error)} = 2,2 \%$
- ◆ “High-quality” analog input module:
 $0,1 \% \text{ (pressure transmitter)} + 0,1 \% \text{ (transmission path)} + 0,1 \% \text{ (analog input module)} + 0,165 \% \text{ (analog input module temperature error)} = 0,465 \%$

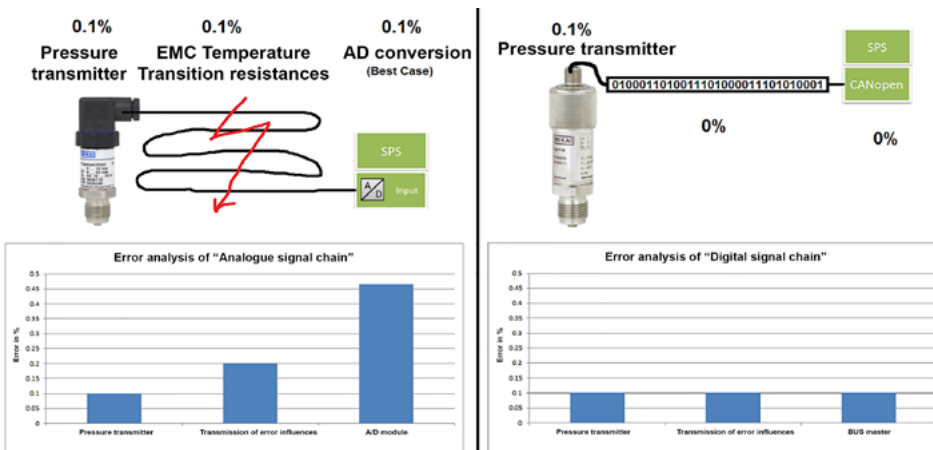

Figure 3: Error analysis of the measuring chain in comparison

The estimation of the digital signal chain, however, turns out to be significantly simpler. Here, the basic accuracy of the pressure transmitter stands (0,1 % in our example), and there are no additional error influences in the onward signal path, so the measured value, which is used in the evaluation process, actually comes with an accuracy of 0,1 %.

Digital systems also offer benefits on the cost side. The additional costs

for sensors with digital interfaces have decreased in recent years. In the example of the pressure transmitter, one supplier of complete pressure transmitter families lets customers choose between analog and digital output signals at no extra charge. The cables required to transmit digital signals are quite expensive when compared to their analog counterpart, though in the case of a bus system, only one line is required. An analog signal transmission cable is required per measurement point, so in total, the wiring for the digital system can be more cost-effective.

Table 1: Comparison of a digital and an analog chain

| Digital signal chain | | Analog signal chain | |
|---|---|---------------------|--|
| Simple cabling, 1 cable for complete bus | + | - | Complicated cabling, 1 cable per measuring point |
| No deterioration in accuracy over the transmission path | + | - | Accuracy deterioration effects on transmission |
| No deterioration in accuracy with the signal evaluation | + | - | Additional measuring errors through A/D module |
| Low cost for bus master | + | - | High cost for A/D module |
| Fault diagnosis | + | - | |
| Parameterization of the measuring points over the bus | | | |

However, the lion's share of the cost is in the signal evaluation. High-quality A/D modules with, for example, 8 analog inputs and 16-bit resolution, come at a price of around €2000. This causes an additional cost of €250 per measurement point. Bus masters for common fieldbuses are in the range €200 to €500, irrespective of the number of required measuring points. In most automation systems, one or more fieldbuses are already in use, so to some extent the cost of the sensor evaluation is already accounted for, since these can be attached to the existing bus.

In summary, digital measuring chains exhibit their strength in applications with multiple measuring points where a secure and accurate transmission of measured values is needed. Particularly in the example of engine test benches that run for considerable periods in an environment where elevated temperatures and also strong EMC interference prevail, using a fully digital measuring chain is recommended. ◀

Authors



Maurice Bildstein, Stefan Heusel
 Wika Alexander Wiegand SE & Co. KG
www.wika.com



CAN/CAN Gateway

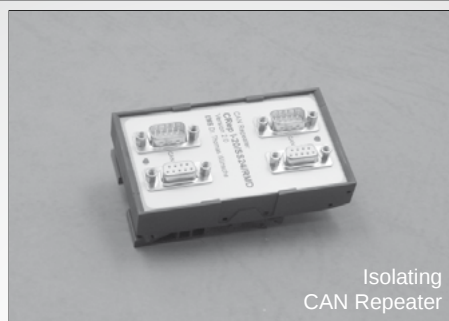

Isolating CAN Repeater

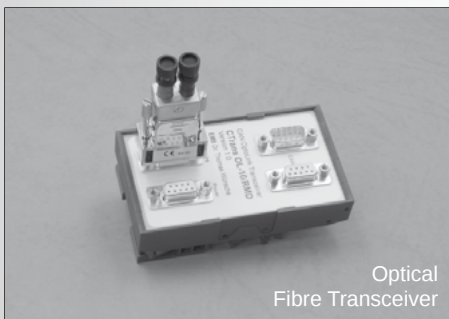

Optical Fibre Transceiver

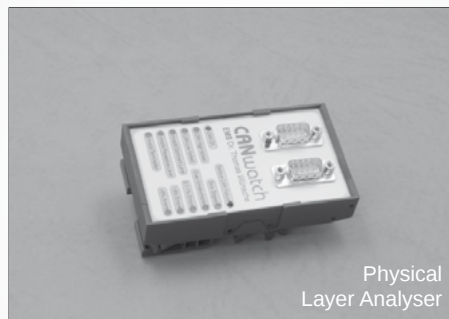

Physical Layer Analyser



Ethernet/CAN Gateway

EtherCAN CI-ARM9/RMD

CAN/Ethernet Gateway
 embedded Linux Kernel 3.5.0
 ARM9 CPU / 454MHz
 2GByte EMMC Flash
 128 MByte RAM

CAN Network Technology

Successfully applied in

- Machine automation
- Building automation
- Transportation systems
- Telecommunication systems

www.ems-wuensche.com

EMS Sonnenhang 3
 D-85304 Ilmmünster
 Tel. +49-8441-490260
 Thomas Wünsche Fax. +49-8441-81860